



OTE TOKEN WHITEPAPER



CONTENT

CHAPTER 1 OTE TOKEN

1.1 About OTE TOKEN	1
1.1.1 Introduction of OTE TOKEN	1
1.1.2 Comprehensive management services	2
1.1.3 Asset value storage and increment	2
1.1.4 Multiple security guarantee	2
1.1.5 Multi-language support	2
1.1.6 Digital asset transaction	3
1.1.7 Risk-free digital assets high frequency automatic quantitative transaction	3
1.1.8 Simple and convenient transaction	15
1.1.9 Convenient deposit tool	15
1.1.10 OTE TOKEN intelligent platform	16
1.1.11 AI & IoT	17
1.1.12 Digital assets bank card	17
1.1.13 Real-time swap	17
1.1.14 Extensive application scenarios	17
1.1.15 OTE TOKEN contracted token	18
1.1.16 OTE TOKEN encrypted algorithm	18
1.1.17 OTE TOKEN universal token-- OTE	18

CHAPTER 2 OTE RELEASE PLAN 19

2.1 OTE release plan	19
----------------------------	----

CHAPTER 3 COST STATEMENT 21

3.1 Cost of computing power	21
3.1.1 Statement of computing power cost	21
3.2 Conversion cost	21
3.2.1 Statement of conversion cost	21
3.3 Commission fee refund	21
3.3.1 Statement of Commission fee refund	21

CHAPTER 4 USER INCENTIVE MERCHANISM 22

4.1 Statement of user incentive	22
---------------------------------------	----

CHAPTER 1 OTE TOKEN

1.1 About OTE TOKEN

1.1.1 Introduction of OTE TOKEN

The OTE TOKEN Digital Asset Intelligent Contracted E-wallet (hereinafter referred to as OTE TOKEN) is a digital asset intelligent DAPP and an e-wallet application in real world. With the multiple intelligent contract blockchain technology, and its high-performance blockchain nodes, OTE TOKEN provides powerful intelligent support for digital assets, and promote the practical application and development of digital assets.

OTE TOKEN provides safe and convenient intelligent solutions by supporting various types of blockchain assets. Users can use the OTE TOKEN for mainstream digital asset for unified storage and management and high frequency automatic quantitative transaction, in which they can not only completely control their own blockchain digital assets, but also effectively improve the practical application of digital assets.

OTE TOKEN is a highly token-accessible blockchain product, supporting Turing complete intelligent contract, and providing secure financial management services for digital assets. Based on blockchain technology, OTE TOKEN platform provides distributed computing capability and distributed API interface for digital assets, greatly enriches the practicability of digital assets.

OTE TOKEN will cooperate in depth with banks and financial institutions to issue digital assets. Users can use OTE TOKEN to recharge digital assets anytime and anywhere, and then consume it at tens of millions of processing outlets and use it in ATM machines. It saves users the hassle of exchanging and managing different fiat currencies and greatly expands the applications of digital assets.

With the continuous development of blockchain technology and digital asset market, OTE TOKEN, as a blockchain digital asset platform, will provide support for more blockchain new projects, improve management and circulation of its blockchain assets, and contribute to improving ecological efficiency and market prosperity of blockchain. For blockchain digital asset to develop over a longer period of time, it must be supported by a wider range of application scenarios. At present, with the deepening of researches in the field of blockchain, especially the exploration in intelligent contract, some blockchain products gradually develop in the field of physical economy, seeking win-win cooperation at the enterprise end. However, the truth is that quite few of them are launched successfully and used in a large scale, much less the services provided to users. Whether it is bitcoin, ETH or all kinds of tokens newly issued on the basis of intelligent contract platform, only when there is more interaction with the real world can the value of digital currency be increased,

thus promoting the market prosperity of digital currency and the efficiency of the real world. OTE TOKEN is committed to providing a safe, convenient and efficient digital assets platform for the public. By connecting digital assets to the real world, we can make everyone use your digital assets conveniently anytime and anywhere, enrich the application scenarios of blockchain technology and digital assets, and promote their service to business progress and social development.

OTE TOKEN is a comprehensive blockchain application consisting of OTE TOKEN intelligent platform, OTE TOKEN and digital asset bank card. With the products and services provided on OTE TOKEN intelligent platform, we can help our customers with rapid deployment of blockchain solutions, while managing BTC, ETH or all kinds of tokens and digital asset transaction. We can also bind your digital assets to bank cards to make a seamless connection between digital asset and physical world, allowing our customers to use digital assets in any transactions and consumption.

Based in the world, OTE TOKEN connects with payment institutions and card issuing institutions to provide users with products and services that comply with the laws and policies of various countries.

1.1.2 Comprehensive management services

Through the unified management of multiple digital assets, OTE TOKEN not only supports the storage and management of mainstream assets such as bitcoin and Ethernet, but also supports the pass-through protocol of intelligent contract platforms such as OTE TOKEN, rapidly increasing the amount of tokens issued on each platform. While reducing the burden of user management, it also provides wallet service support for ICO new projects, enabling the project team to focus more on core services.

1.1.3 Asset value storage and increment

OTE TOKEN adheres to the core of block chain and will provide users with digital asset value storage and increment proposal.

1.1.4 Multiple security guarantee

OTE TOKEN provides multiple signature technology guarantee and two-step authorization verification for digital asset management of different scales. Users can choose verification methods such as biometric indicators for transactions when transmitting. It also supports the connection of hardware wallets, such as Ledger Nano S, which stores the private keys of digital assets in the hardware device to fully ensure the security of digital currency assets.

1.1.5 Multi-language support

OTE TOKEN will support multiple languages in mainstream digital asset markets such as the USA, UK, China, Korea and Japan, clearing language barriers for building world-class wallet applications.

1.1.6 Digital asset transaction

OTE TOKEN provides users with simple, convenient and safe payment and trading services through the unique cross-border payment and small payment network, as well as docking with exchange APIs.

1.1.7 Risk-free digital assets high-frequency automatic quantitative transaction

OTE TOKEN is based on the development of risk-free digital asset trading services through intelligent contract, cross-chain gateway and inter-intelligent contract technology. Users conduct transactions between digital assets through OTE TOKEN, and intelligent contracts for transactions are created by the platform or other third parties. The contract mechanism monitors and executes the transaction process, avoiding the default risk of each party involved in the transaction. The new token supported by OTE TOKEN enables risk-free transactions through the wallet service.

Development of high-frequency automatic quantitative transaction

DROPS DETECTION

This method is giving a signal on price drop for a specified percentage. Using this strategy you can configure different bot behavior depending on the daily trading volume on the coin, on the specific coins listed in the whitelist, and adjust for them different levels of buy price, sell price and stops.

WALLS DETECTION

The method reveals coins with a large volume of buy orders for a long time (support). The example in figure blow:

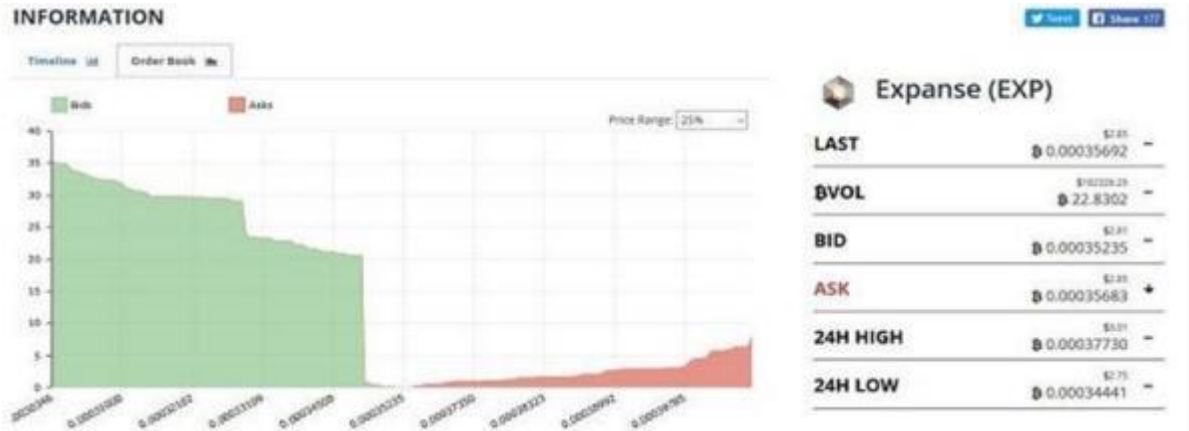

Configure parameters to specify a period to check how long the support was there; AI-Starlink will execute the checks.

Example of the Walls strategy: copy the text below and paste it to AI-Starlink

```
##Begin_Strategy
Active=- 1
StrategyName=Walls Test
Comment=AI-Starlink
SignalType=WallsDetection
ChannelName=
ChannelKey=
SilentNoCharts=NO
ReportToTelegram=YES
OTECoinsWhiteList=
OTECoinsBlackList=TRX,NBT
MinVolume= 10
MaxVolume=500
AutoBuy=NO
MaxActiveOrders= 10
AutoCancelBuy= 180
BuyType=Buy OrderSize=0.00000000 buyPrice=-3.00000000 ● SellPrice=4.00000000
UseStopLoss=NO
StopLoss= 1.00000000
PanicSellSpread=0.10000000
AllowedDrop=0.00000000
UseTrailing=YES
TrailingPercent=- 1.00000000
UseTakeProfit=YES
TakeProfit=2.50000000
```

```

DropsMaxTime=600
DropsPriceMA= 1
DropsLastPriceMA= 1
DropsPriceDelta= 1.00000000
DropsPriceIsLow=NO
WallsMaxTime=3600
WallsPriceDelta=4.00000000
WallBuyVolDeep=2.00000000
WallBuyVolume= 10
WallBuyVolToDailyVol=10.00000000
WallSellVolToBuy=75.00000000
WallSellVolDeep= 15.00000000
##End_Strategy#

```

PUMPS DETECTION

Fast detecting of executed buy orders (market history). Example: (false detection by the way, look warning below)

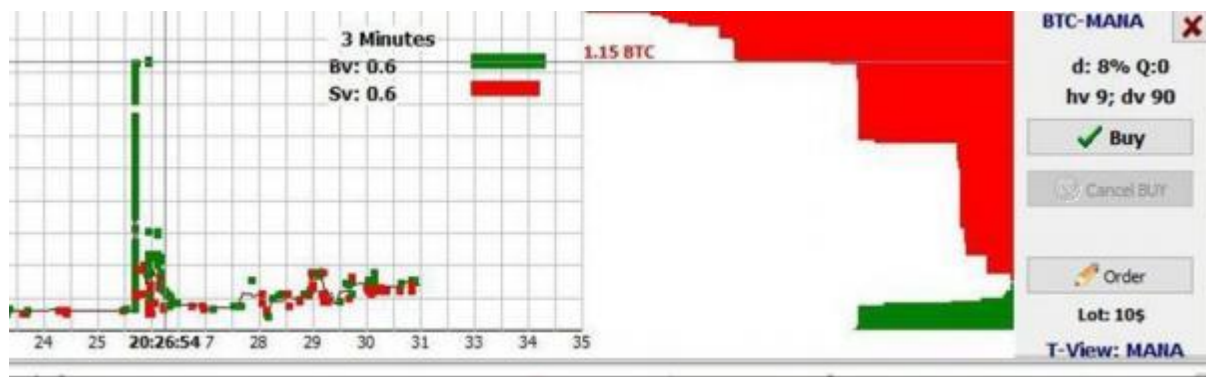

The thin green candle is a pack of buy orders executed in a second. (Actually that was 1 buyer which bought plenty of MANA for 11 BTC).

Currently only 1 Pumps Detection strategy can be active despite you can configure many of them.

It's recommended to use Pump Detection only for known in advance pumps when you know exact pump time. Turn it ON 15 seconds before the pump announcement and turn OFF immediately after.

WARNING! There is a high risk of false detection! Despite you can configure many parameters to avoid them, it is still possible that some market activity could be taken as a pump. Look the example of MANA above.

Recommended parameters values for binance pump detection on the example of Mega Pump Group actual pumps (mega_pump_group)

PumpPriceRaise: =7; - 7% Price increase for the last 30 seconds. The more this value, the less chance of false detection, on the other hand, you might want to detect a pump as soon as possible when the price is not very high yet.

PumpBuysPerSec: =20;

PumpVolPerSec: =0.8; The volume added by the very first buyers. (Usually admins and provedged members of the discord group). The more this value, the less chance of false detection

PumpBuyersPerSecMax: =4; The goal is to detect the pump at the very beginning when no more then 2-4 ppl already bought the TOKEN.

PumpBuyersPerSecMin: =2; Reject a case when there is only 1 buyer occasionally bought some TOKEN not related to the pump

STARLINKSHOT (BUY ON SPIKES):

The strategy puts buy orders and automatically replace them in order to catch spikes. (Look picture below) Initially, the order is placed at a price below the market price on YLShotPrice (in the example below 3%). With a further price drop to YLShotPriceMin (in the example of 2%), the order is replaced on YLShotPrice from the current market price. If the price increases, the order moves up. Thus, the order price is always in the range from YLShotPrice to YLShotPriceMin.



Using the delay (YLShotReplaceDelay) you can slow order's replacing on downtrend; this is more risky but gives more actual trades. If YLShotReplaceDelay=0 then order will catch only spikes like in picture above; this is less risky but happens less often.

Use delay on prize raise (YLShotRaiseWait) to avoid moving order up on fast pumps (which is very risky). Also protect from catch on dumps by using strategy daily volume filters (flash pumps could happen only on TOKEN with low daily vol.)

With a relatively rapid drop in prices, it makes sense to use the YLShotReplaceDelay delay to swap the buy order; In this case, the probability of a transaction increases, but the risk also increases. The detector uses 4 intervals to check that the average prices and volumes grew from previous to next interval. Growth is set in percent. If you set 0 percent, then the condition turns into "price (volume) did not fall." If you specify -1000 on any interval, then the check on this interval is disabled.

Picture to illustrate: P - Prices, V - Volumes



Parameters:

- VLiteT0 .. VLiteT3: Intervals, seconds
- VLiteP1 .. VLiteP3: How much the avg. price raised from prev. interval to next one (%)
- VLiteMaxP: Price raised not more then (%) (helps to reject flash pumps-dumps detections, we are looking for smooth natural growth)
- VLitePDelta1, VLitePDelta2: Compare price raise percentage between each other, %. (Example: P1=1%, P2=2%, P3=1%. this means that on the last interval growth was less than on prev.; in this case PDelta1=100% (1% to 2%), PDelta2=-100% (2% to 1%)).
- VLiteDelta0: Price change in T0 interval (difference between max. and min. prices within the interval), %
- VLiteMaxSpike: Max. Price to avg. price, not more then (%). Reject spikes.
- VLiteV1 .. VLiteV3: How much the avg. Volume raised from prev. interval to next one (%)
- VLiteDetectPenalty: Penalty for new detection after successful one, seconds.
- VLiteWeightedAvg: If YES then calculate weighted price average else trades count average (sum of prices / sum of trades)

The idea is the same as Volumes Lite: The detector uses 4 intervals to check prices and volumes deviation from previous to next interval. Unlike Volumes Lite, negative parameter means that the value has dropped, positive means the value has raised, zero parameter will be ignored.

Parameters: P - Prices, V - Volumes

- WavesT0 .. WavesT3: Intervals, seconds
- WavesP1 .. WavesP3 : How much the avg. price changed from prev. interval to next one (%). Negative parameter means that the value has dropped, positive means the value has raised, zero parameter will be ignored.
- WavesDelta0: Price change in T0 interval (difference between max. and min. prices within the interval), %. Negative parameter means that the value has dropped, positive means the value has raised, zero parameter will be ignored.

- WavesMaxSpike: Max. Price to avg. price, not more then (%). Reject spikes.
- WavesV1 .. WavesV3: How much the avg. Volume changed from prev. interval to next one (%). Negative parameter means that the value has dropped, positive means the value has raised, zero parameter will be ignored.
- WavesDetectPenalty: Penalty for new detection after successful one, seconds.
- WavesWeightedAvg: If YES then calculate weighted price average else trades count average (sum of prices / sum of trades)

DELTA (PRICE\VOLUMES DEVIATION)

Parameters:

- . DeltaInterval: Interval for price and volumes analyzing, seconds (long interval 300 or more sec.)
- . DeltaShortInterval: Interval for calculating moving average, seconds (short interval, 2..10 seconds.)
- . DeltaPrice: Price change on long interval (delta, %), greater then. Calculated as difference between max. and min. point on moving average curve
- . DeltaVol: Total volume (buy + sell) on long interval greater then (BTC)
- . DeltaVolRaise: Total volume on long interval has raised more than the same volume on the previous long interval (% , 0% means the volume is not less than prev. volume)
- . DeltaVolSec: Volume in last seconds calculated with spikes removed. Use to reject detecting of spike. If 0 then ignored. (We may adjust the calculating method in future, its experimental parameter)
- . DeltaBuyers: Buyers count on short interval greater then
- . DeltaLastPrice: Last Price (on short interval) changed in compare to average price (on long interval). If the value is positive, we check if price has raised. If negative, check if price has dropped. If 0, the parameter is ignored.
- . DeltaDetectPenalty: Penalty for repeat detection, seconds.

COMBO

Combo is a pair of 2 strategies ("Start" + "End"), which works together: after the first strategy "Start" has signalled, AI-Starlink starts wait for the second strategy "End" for the specified time. If the "End" strategy has signalled during wait period, AI-Starlink will buy token and use Combo strategy settings to trade it. Otherwise the bot waits for the "Start" strategy again.

Note: in both the "Start" and "End" strategies, AI-Starlink should be turned on!

All 3 strategies must be active.

Parameters:

- . ComboStart: The first strategy
- . ComboEnd: The second strategy

- . ComboDelayMin: Time between 1st and 2nd strategy signals, not less then, seconds
- . ComboDelayMax: Time between 1st and 2nd strategy signals, not more then, seconds

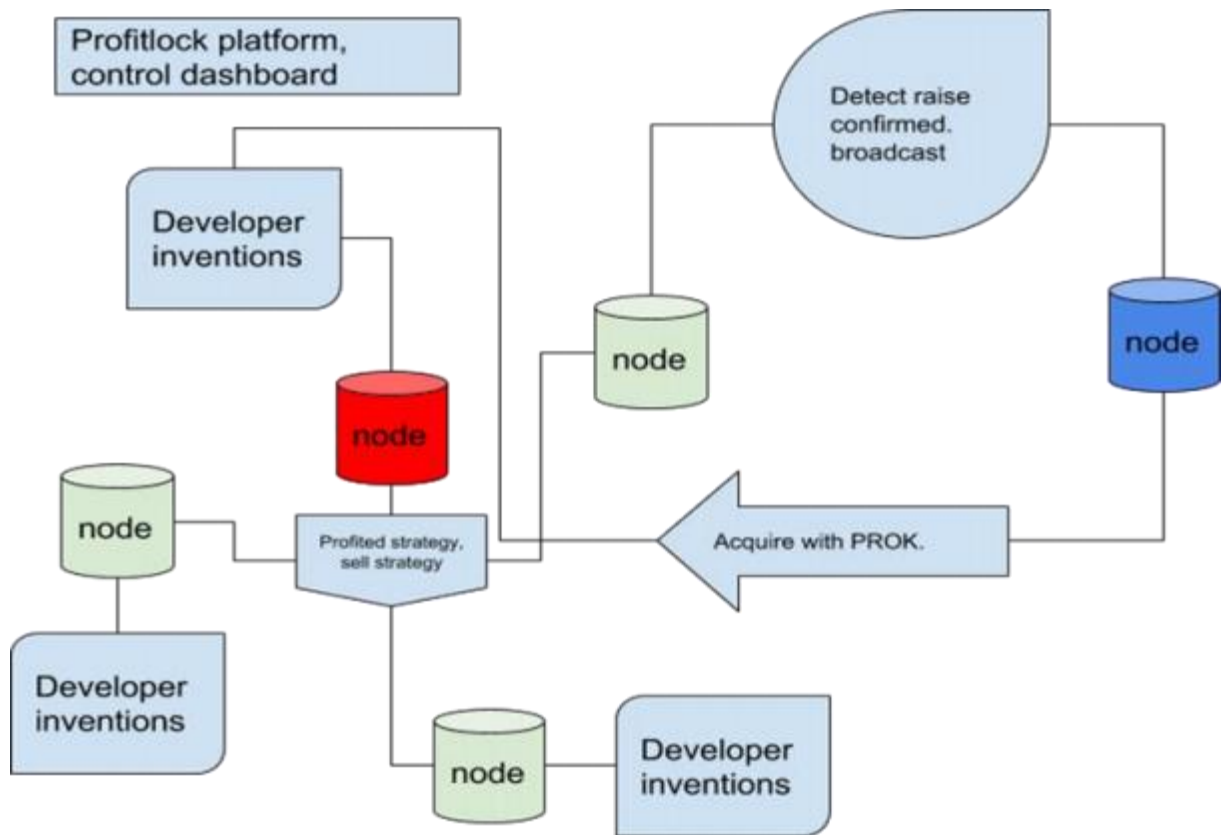

In the process of algorithm development, we are looking to create a sandbox like AI-Starlink intelligent platform, which will initiative talented algorithm developers and data scientists using our platform. Our vision is to provide a coded block algorithm pool based on the blockchain repository, allow more people to join the algorithm community and provide users of OTE TOKEN with self learning AI-Starlink sandbox, to test the distributed AI-Starlink algorithm for developing OTE TOKEN intelligent platform. In the process of realizing this vision, we must finish the work of early development. By running extensible blockchain technology in OTE TOKEN and providing advanced high-frequency automatic quantitative transaction protocol for the interaction between the trading and exchange, we will push our vision and thrive it in the future, and will share all the result of algorithmic research to OTE TOKEN users.

Details of algorithmic economy

- OTE market transparency
- Accuracy of prediction
- Mapping of trading volume

The weighted average score (alpha) will be listed. Developers is rewarded within a period of time (t) according to the score consistency (φ). The result is the score can be added to AI-Starlink as a reward.

$$w = \varphi \alpha t$$

By making these algorithms available for AI-Starlink developers, sellers must use more than 30% OTE on the pre-release or released OTE strategy, or use an equal amount of OTE and rank the score according to the result of **w**. Verifying their work and result will be executed in the IOTA network with registered ID. In this way, the network will transparently provide the original developers with credit and iteration progress.

When strategies are consistent with the given rankings, constant **w** will become larger, and the likelihood of success in a single market will increase, and meanwhile the scale will increase, which will allow others to affect the strategy. By allowing knowledge to be shared on the fairway, the consent system is introduced into the network. The consent system allows a majority of the votes (at least 51%) composed of member investors, shareholders, equity developers and AI-Starlink networks to obtain or merge another AI-Starlink or delete out of date strategy. Along with the development and operation way, the ecological system can continue to better algorithms and exit the bad algorithms

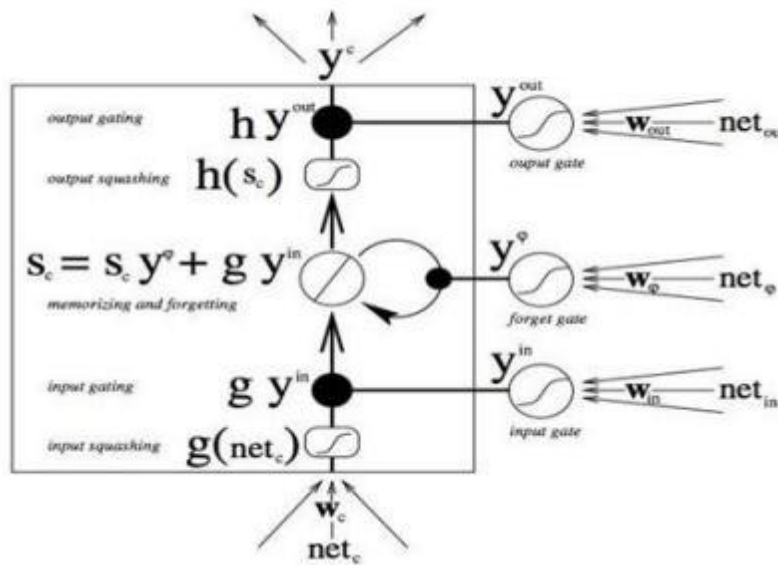

LSTMs is a major step we can complete the RNNs.

Market analysis of technical indicators has many different technical indicators. The scope of "Technical analysis" of transactions is wide. Most of them are not within our scope, so we will just put forward three simple technical indicators. Different indicator focus on different tasks. The concept of trend may be an important concept in technical analysis. The definition of finance is not exactly the same as the general definition of this term - a trend is actually just the general direction of security or market.

MACD

Moving average convergence/divergence oscillator (MACD) is one of simple and effective momentum indicators. By subtracting a longer moving average (MA) from the shorter MA, the MACD transforms the two trend tracking index into a momentum oscillation index, moving the MA to the momentum oscillation index.

Quantitative indicator market dynamics is an indicator of overall market sentiment that can support buying and selling of market trends. There are several market factors and indicators that can help investors follow market dynamics.

Quantizing oscillator

The quantization oscillator is a momentum pointer that shows the position of the oscillator relative to the high and low region over a certain period of time.

High frequency indicator

The volume of high-frequency automated quantitative trading is the number of OTE or contracts traded across the market in a given period of time.

Average true range (ATR)

ATR is a technical pointer to volatility (not price). big:

- A: The current high and low current low method
- B: Closed before the current high and low (absolute value)
- C: The current is lower than the previous close (absolute value)

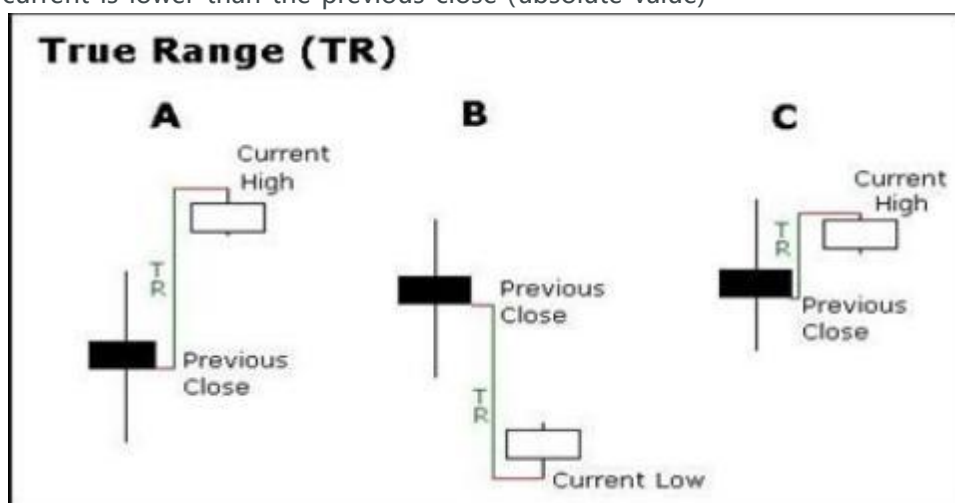

Depth regression by implementing the above index model and strategy, we will be able to do the development the influence of pricing model, and produce better results from the depth of the neural network.



Market analysis

The proposed price forecasting platform tool will use regression line projection RNN for market analysis. The whole idea is made up of a series of words and sequence of words that encode a lot of information that helps predict what's going on. Step 1 is to map the word to the word embed. Step 2 is to take the sequence of received vectors as input and consider the sequence of vectors to generate the predicted RNN. From the embedded layer, the new representation is passed to the LSTM unit. These additions will always connect to the network, so we can include information about word sequences in the data.

Use a function (with parameters) to approximate the Q-function

- Linear
- Non-linear: **Q-Network**



$$Q(s, a; \theta) \approx Q^*(s, a)$$



The next step is to focus on the analysis! "The idea is to have the RNN pick information from more information at every step. Recent studies have shown that RAM frequently paying attention to the network can provide binary advice on a set of run data.

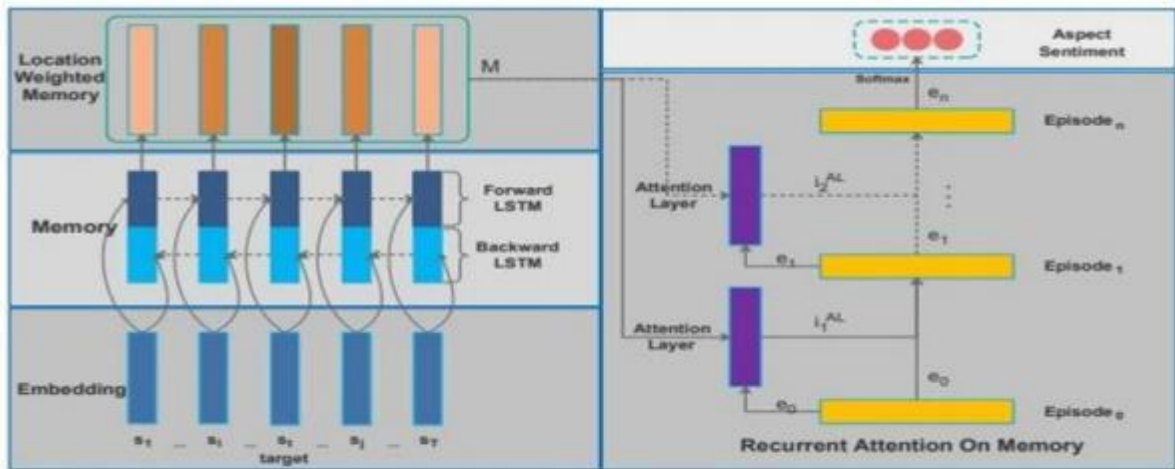

Figure 1: Model architecture. The dotted lines on the right indicate a layer may or may not be added.

Deep high-frequency quantitative trader

Bellman equation

The optimal Q-value function Q^* is the maximum expected cumulative reward achievable from a given (state, action) pair:

$$Q^*(s, a) = \max_{\pi} \mathbb{E} \left[\sum_{t \geq 0} \gamma^t r_t | s_0 = s, a_0 = a, \pi \right]$$

High-frequency quantitative trading has great potential to extend its utility to the financial world. Based on enhanced high-frequency quantitative trading, it has the results of actions and factor of incentive randomness. It is perfectly suited to constantly hunting down prices from the crypto-digital asset market. The power of the high frequency quantization function is that it combines the strategy gradient and quantitative trading learning on one player (strategy) and one commentator (function).

```

Initialize policy parameters  $\theta$ , critic parameters  $\phi$ 
For iteration=1, 2 ... do
  Sample m trajectories under the current policy
   $\Delta\theta \leftarrow 0$ 
  For i=1, ..., m do
    For t=1, ..., T do
      
$$A_t = \sum_{t' \geq t} \gamma^{t'-t} r_{t'}^i - V_{\phi}(s_t^i)$$

      
$$\Delta\theta \leftarrow \Delta\theta + A_t \nabla_{\theta} \log(a_t^i | s_t^i)$$

      
$$\Delta\phi \leftarrow \sum_i \sum_t \nabla_{\phi} \|A_t^i\|^2$$

      
$$\theta \leftarrow \alpha \Delta\theta$$

      
$$\phi \leftarrow \beta \Delta\phi$$

    End for
  End for

```

Using the above AI-Starlink optimization equation to realize quantitation of function. Although the quantitative function is the general method to adjust the mood of market and input of strategic tool, the iteration of quantitative function will pass through the market value to push itself, and generate the insight from the trend.

The combination of autonomous control layer

By using these two learning algorithms, price forecast can be to complete by applying these modules in data flow. Reinforcement learning is a part of high frequency automatic quantitative transaction. Users will bring their own training models of high frequency automatic quantitative transaction to the platform and keep it continue to evolve into other descendants model .As everyone can submit their strategy model on the platform, the study of iteration will increase the vitality of model generation. In the process of development of AI-Starlink algorithm, we are creating a sandbox like AI-Starlink intelligent platform, which will drive talented developers and settlement data scientists to use our OTE TOKEN intelligent platform.

OTE TOKEN basic reward system

Based on intelligent contract blockchain network, we will integrate IOTA, Waves, TRON, RSK, BSC, Ethereum and variety existing technologies, to build our basic reward system. The reward is generated by a given consistency algorithm. Inheritance of competition in actual market prices will depend on price forecasting and specific market relevance of the executable entry and exit points. Relevant points will be given according to the weighting factor to AI-Starlink of how to operate with its OTE. According to all these successful events, AI-Starlink will receive the reward of the token system.

Simulation tests will be reflected on the wall, for the use of all the audience. Distributed AI-Starlink network economy (DAN).

Our vision is to provide a coded block algorithm pool based on blockchain repository, allow more people to join the algorithm community, and provide others with AI-Starlink trading computing power, to test the distributed AI-Starlink algorithm development platform. In the process of realizing this vision, we must finish the work of early development. With extensible distributed network operating in exchange, and provide the advanced trading license agreement, between the decentralized exchange and centralized exchange certificate. We will push our vision and thrive in the future, and will make all the AI-Starlink computing power research are available within the scope of the blockchain business.

1.1.8 Simple and convenient transaction

By connecting exchange API, OTE TOKEN can provide users with the best market prices and simple operation experience of transaction. Through optimizing selection mechanism, OTE TOKEN can present the buy and sell rate in a simple way and entrance to high frequency automatic quantitative transaction. Users only need to enter, then they can easily complete the trading and participate in the incentive mechanism.



1.1.9 Convenient deposit tool

By connecting international payment service providers, OTE TOKEN provides users with bank card pay channel. Users only need to initiate purchase order in OTE TOKEN, settlement by OTE

TOKEN realize the five mainstream currency including US dollar, Hong Kong dollars, yen, euro, pound import to complete high frequency automatic quantitative transaction of digital assets.

1.1.10 OTE TOKEN intelligent platform

OTE TOKEN intelligent platform is turing-complete contract, designed to provide digital asset transfer and exchange and professional financial services, OTE TOKEN intelligent platform will generate financial related intelligent contract, solving the problem of digital assets safety certification. OTE TOKEN intelligent platform focused on financial function of digital assets, with safety and high performance, no redundant data.

In OTE TOKEN of intelligent platform design concept, digital assets itself through high frequency automatic quantitative transaction complete generated related miners fee returns, by the incentive mechanism. The incentive mechanism needs some decentralized data or transaction mining services, in OTE TOKEN intelligent platform of digital assets generate configured corresponding functions in the contract, at the same time provide the data generated or mining algorithms, and deposited in the corresponding number of digital assets, a high frequency automatic quantitative transaction programs, so there will be a lot of OTE TOKEN users will run the program or data mining application for the digital assets to provide the data or mining services, earning OTE and corresponding digital assets. Posted on the OTE TOKEN intelligent platform for algorithm and deposit a certain amount of digital assets, OTE TOKEN intelligent platform users found running on high frequency automatic quantitative transaction programs can earn good OTE and the digital assets of the contract, will provide the digital assets decentralization of data services. In OTE TOKEN of intelligent platform, project parties only need to configured in the corresponding data in their digital assets, such as blockchain pattern, the block size, the consensus mechanism, the mining mode, etc, and deposit a certain amount of OTE, then OTE TOKEN intelligent platform will match the demand, will switch some trade workforce to generate the intelligent contract agreement to support the project block for OTE, and the corresponding digital assets. OTE TOKEN intelligent platform trade through the automatic configuration force to make good profits. For project party, could be as simple as deposited in the digital assets to obtain decentralized intelligent contract agreement and the corresponding support. In this way, digital assets are completely separated from commercial applications to solve performance problems and make digital assets more secure.

If the business application of the project party is not satisfied, OTE TOKEN intelligent platform can also provide smart contract --centralized service program, deposited in the digital assets, posted on the OTE TOKEN intelligent platform, there will be OTE TOKEN users with provide the computing power.

In the whole framework, the design of project digital assets is completely decentralized, the credibility is very trustworthy. OTE TOKEN and OTE TOKEN intelligent platform architecture design, completely solve the high cost and difficulty and computing power waste problems in blockchain development.

1.1.11 AI & IoT

The era of AI and the Internet of Things is coming, and blockchain and digital assets on blockchain are indispensable for them. Blockchain is the best carrier for artificial intelligence and Internet of things. OTE TOKEN can automatically complete all kinds of digital assets transaction through our unique cross-chain and cross-intelligent contract technology. OTE TOKEN will be the basis of communication between AI and Internet of Things.

1.1.12 Digital assets bank card

In order to connect digital assets and the physical world, OTE TOKEN is piloting bank card services. Through cooperation with card issuers, users are allowed to apply for physical cards and recharge the physical cards with digital assets to promote circulation and consumption in the physical world. Currently, the OTE TOKEN team has filled in the gaps with card issuers and is preparing to issue bank cards that can be used for digital assets.

1.1.13 Real-time swap

When users need to use bank cards for offline payment, they can recharge any digital assets stored in OTE TOKEN for trading. In this way, users are allowed to hold digital assets in their e-wallet accounts, and convert to local currencies when trading.

1.1.14 Extensive application scenarios

OTE TOKEN cards issued through bank cards can be used for offline transactions. Existing ATMs offer higher interest rates and are more efficient than traditional methods. At the same time, through cooperation with financial institutions, OTE TOKEN cards can be consumed at its tens of millions of processing outlets, and cash can also be withdrawn from ATMs in more than 200 countries and regions around the world.

1.1.15 OTE TOKEN contracted token

OTE TOKEN contracted token refers to the ability of the certifier to convince the verifier of the correctness without providing any useful information to the verifier. Using contracted token, OTE TOKEN complete the technology of cross - chain and cross - Intelligent contract.

1.1.16 OTE TOKEN encrypted algorithm

Designed by SHA (Secure Hash Algorithm) is the national security agency (NSA), the U.S. national institute of standards and technology (NIST) released a series of cryptographic Hash functions.

By customizing OTE TOKEN encryption technology, we guarantee OTE TOKEN network data security.

1.1.17 OTE TOKEN universal token-- OTE

OTE is a network digital asset developed based on blockchain, "PtoP" distributed technology and secured by encrypted algorithm. OTE will be OTE TOKEN universal token used extensively for distribution, payment and liquidation.

Chapter 2 OTE Release Plan

2.1 OTE release plan

OTE is the token issued by OTE TOKEN, total circulation is 500 million. Below is the allocation plan:

Proportion	Allocation	The detail	Note
2%	Pre-sale	Use for OTE TOKEN project follow-up development, talent recruitment, marketing, etc.	Giving back to the early contributors.
30%	Trading mining services, etc.	User can use on OTE TOKEN platforms, provide computing power and data support, trading services such as mining for OTE TOKEN and to obtain rewards.	This part 30% of total, will never increase issue, in later stage will start profit repurchase plan.
8%	Community rewards	To reward users to download, promotion, save money, cash, airlift, consumption, transfer, etc.	Contribution to the global community of users.
10%	Institutional investors	Used to return early enterprises investors, establishing business cooperation and enterprises cooperative.	OTE issue this section of OTE will be lock with smart contract, start with one month after listed on exchange, unlock this section 20% every year, 5 years to unlock whole.
40%	Founding team	For return founding team in exploration and development in the field of digital assets and future maintenance of OTE TOKEN product technology and operation development, grant OTE in return.	OTE issued this section of OTE will be lock with smart contract, start with one month after listed on exchange, unlock this section 10% every year, 10 years to unlock whole.

<p>10%</p>	<p>The foundation</p>	<p>As the development of OTE reserve funds, for follow-up project development and business ecological construction and international cross-border payment business development.</p>	<p>The use of this part of the funds required Foundation resolution, and make public notice in advance.</p>
------------	-----------------------	---	---

Chapter 3 Cost Statement

3.1 Cost of computing power

3.1.1 Statement of computing power cost

On OTE TOKEN intelligent platform, if the project party need to generate an agreement in a short time. They need to deposit a certain number of digital assets in Contract assets in the contract, to attract the miners to provide computing power. Also, if the project require the user to provide decentralized computing power, the data mining service support and transaction mining services, project party also need to pay digital assets in advance.

3.2 Conversion cost

3.2.1 Statement of conversion cost

User need to complete the conversion between different digital assets, need to pay certain amount of fees for decentralized exchange service.

3.3 Commission fee refund

3.3.1 Statement of Commission fee refund

When OTE TOKEN is used to carry out high-frequency automatic quantization transaction of digital assets. According to the current market value of OTE, the fees generated will be returned to the users.

Chapter 4 User Incentive Mechanism

4.1 Statement of user incentive

OTE TOKEN users can play the role of the creator of the contract in OTE TOKEN high frequency automatic quantitative digital asset transactions, obtain more OTE revenue by high frequency automatic quantitative transaction.